

AD. CARRIEL SUR (INTL OR) CONCEPCION - CHILE

SCIE IAC 1
ILS RWY 02

APP CONCEPCION <i>Concepción Approach</i>		120.5	TORRE CONCEPCION <i>Concepción Tower</i>		118.1	CONTROL TERRESTRE <i>Ground Control</i>		121.9
LOC ICEP 109.9	FINAL APCH CRS 017°	GS LOM 1700' (1674')	ILS DA (H) 226' (200')	AD Elev. 26'	THR 02 Elev. 26'			
APCH FRUSTRADA: Ascenso 3500' HDG 017°, luego según autorización ATC. <i>Missed Apch: Climb to 3500' on HDG 017°, then according to ATC clearance.</i>								

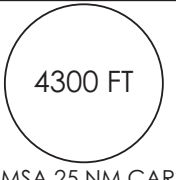
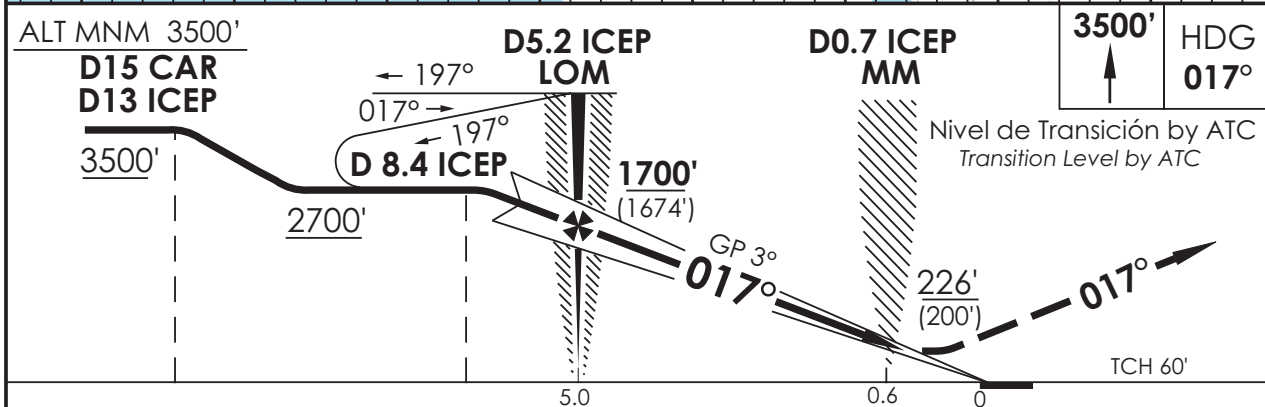
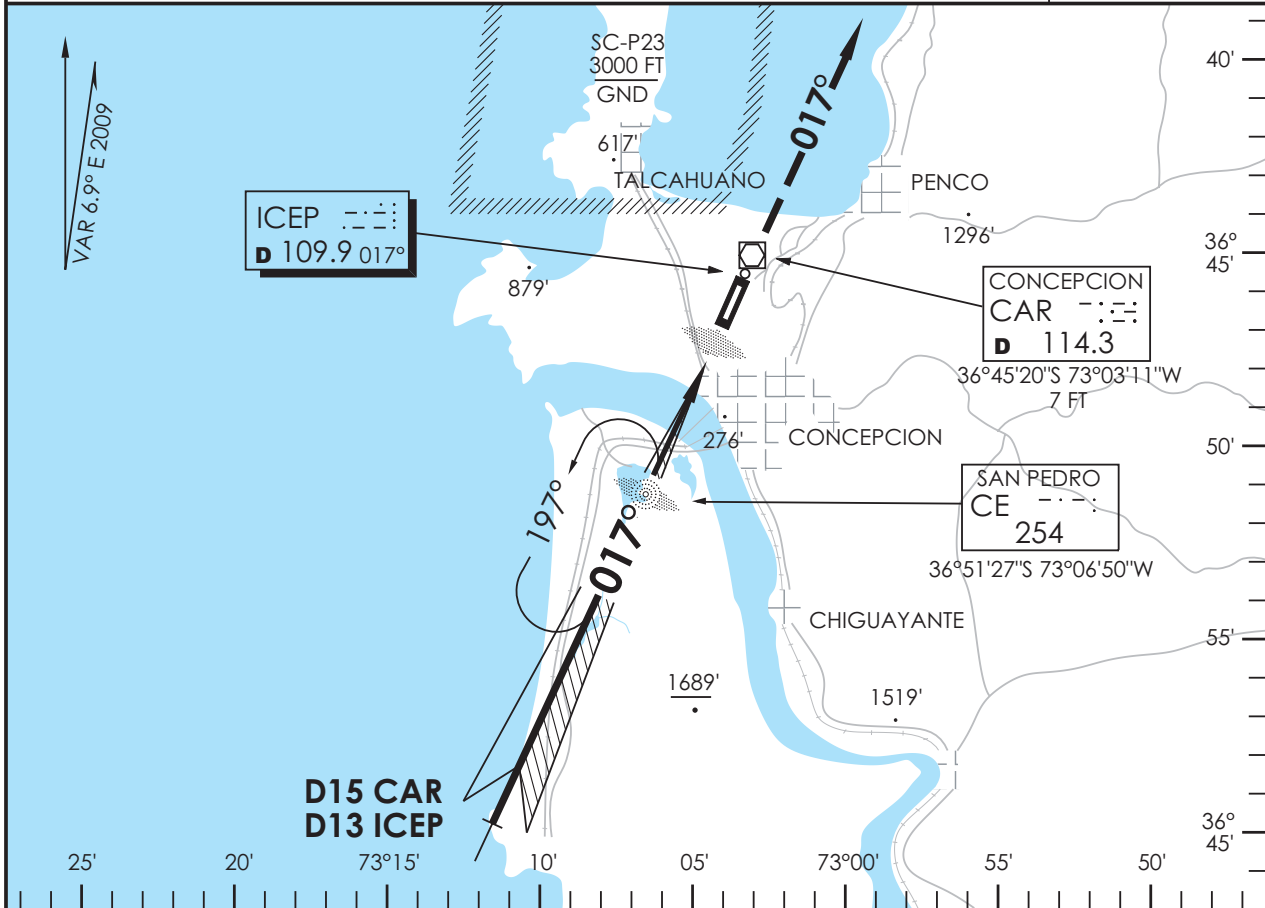

CATEGORIA	DIRECTO RWY 02 <i>Straight in RWY 02</i>				CIRCULANDO <i>Circling</i>		ALTN <i>Alternate Minimums</i>	
	ILS DA 226' (200')		LOC WO GP MDA 360' (334')					
	ALS	WO ALS	ALS	WO ALS				
A	RVR 550m*	1.2 Km	0.8 Km	1.6 Km	540' (514)	1.6 Km	(600')	3.2 Km
B	RVR 750m				620' (594')			
C	o				680' (654)			
D	0.8 Km							

* Ver pagina GEN 2.20 / See page GEN 2.20

Veloc. Terrestre Kts	70	90	100	120	140	160
GP 3° FPM	382'	491'	545'	654'	763'	872'
MIN:SEC (FAF TO MAPt 4.4)	3:46	2:56	2:38	2:12	1:53	1:39

CAMBIO: VAR
Change: VAR

DGAC AMDT 67

17 DICIEMBRE 2009

DASA / SECCION AIS-MAP